

11 PORTA P01b
ESCALA: 1:25

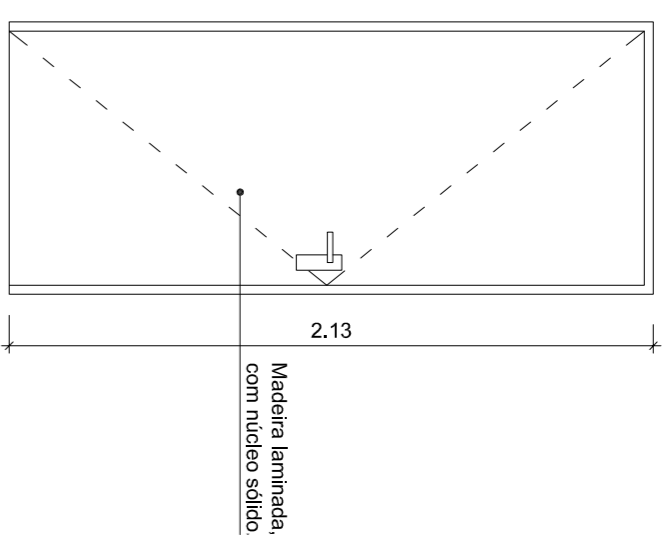

12 PORTA P03
ESCALA: 1:25

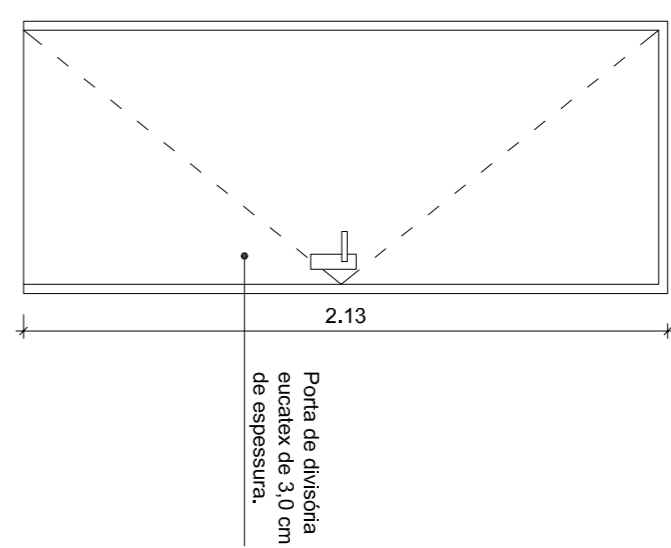

13 PORTA P04
ESCALA: 1:25

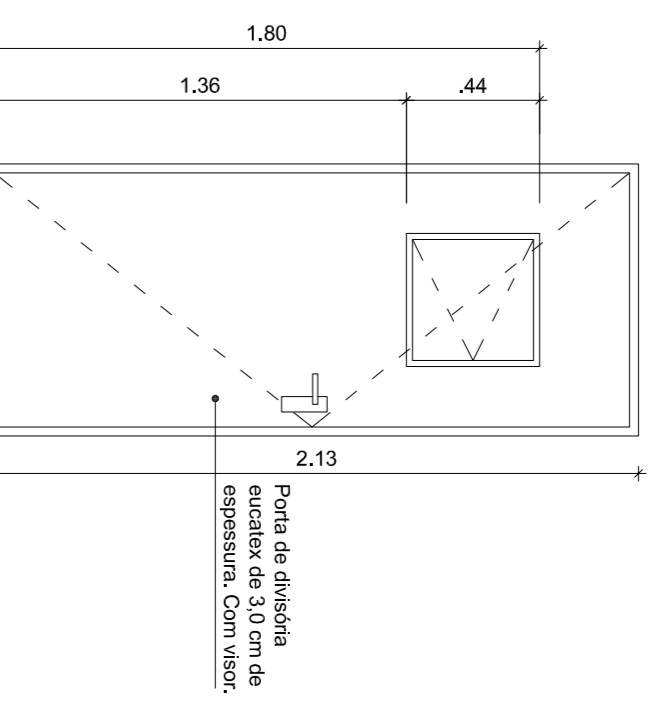

14 PORTA P04a
ESCALA: 1:25

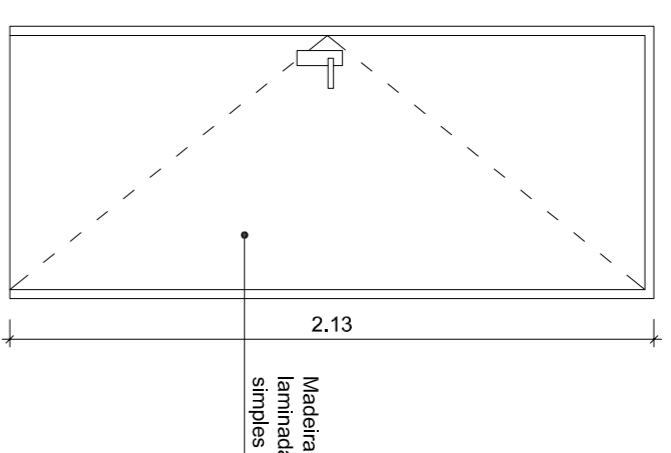

15 PORTA P05
ESCALA: 1:25

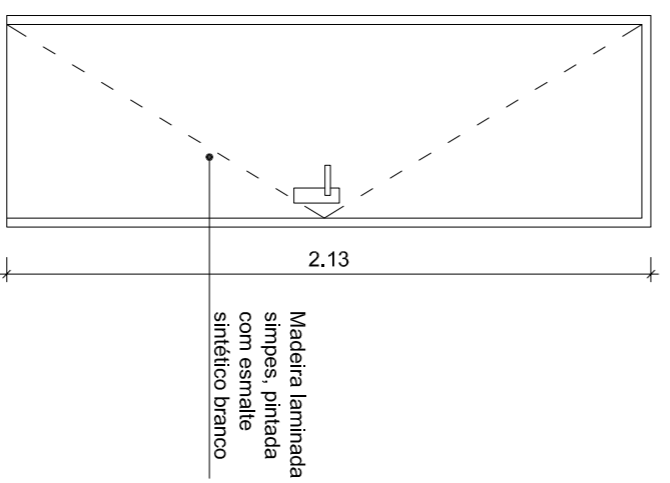
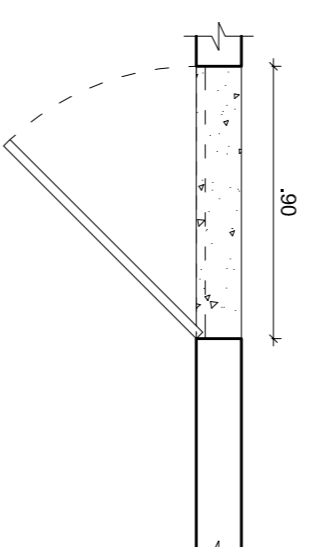
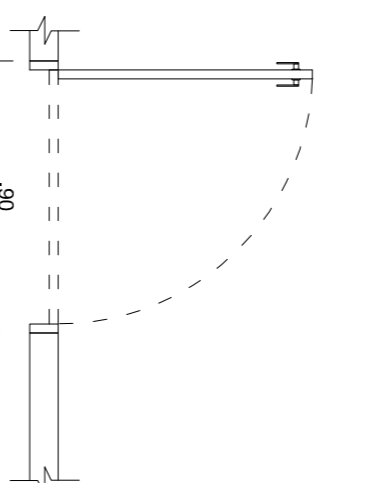
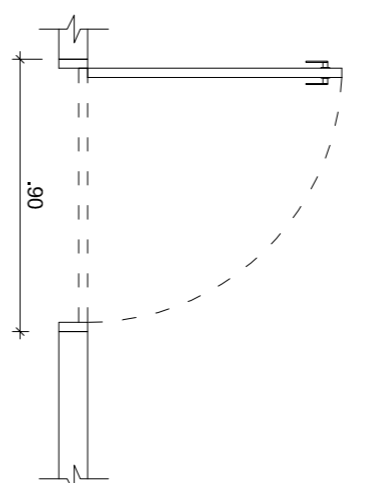
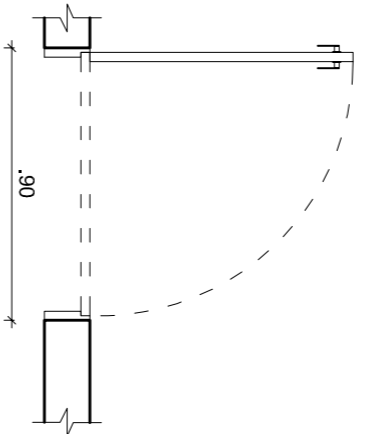
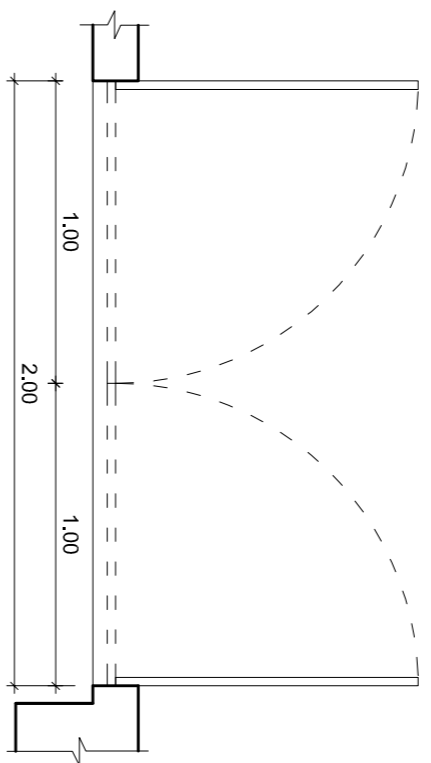

18 JANELA J08
ESCALA: 1:25

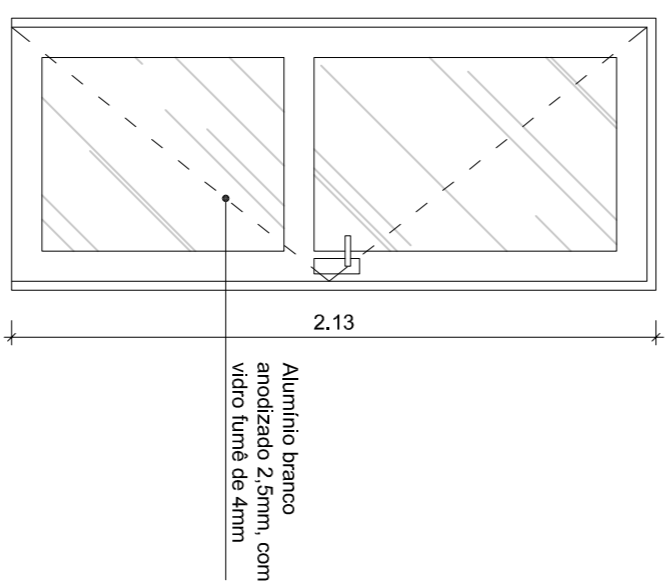

19 JANELA J09
ESCALA: 1:25

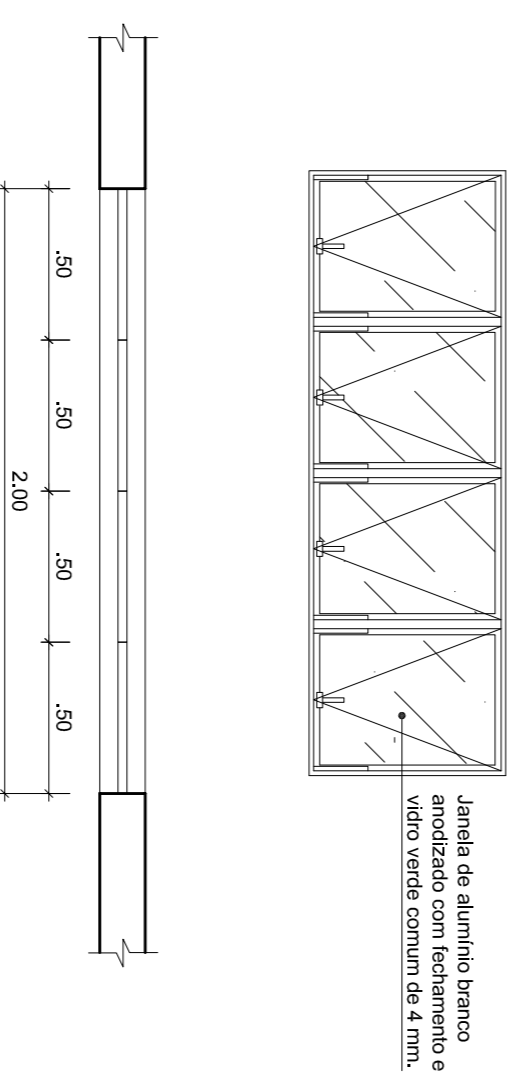

20 JANELA J10
ESCALA: 1:25

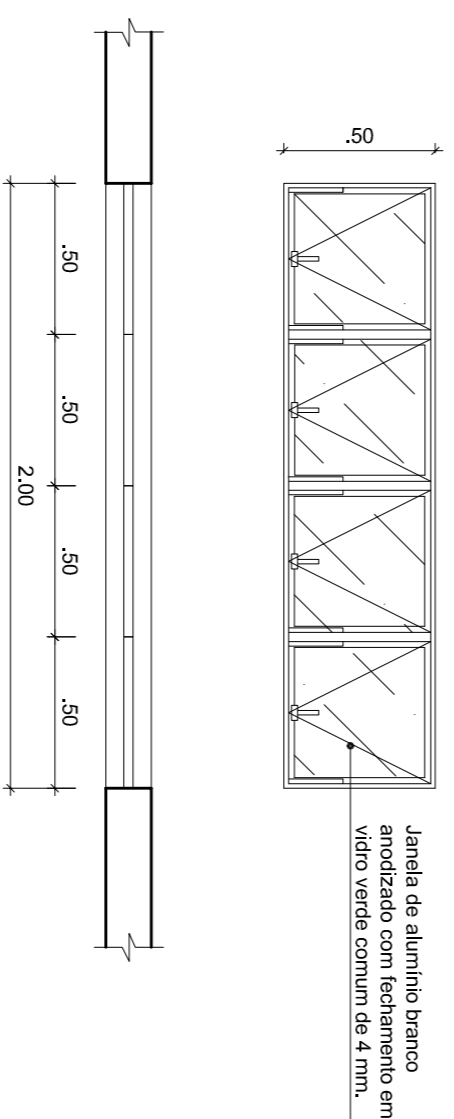

21 JANELA J11
ESCALA: 1:25

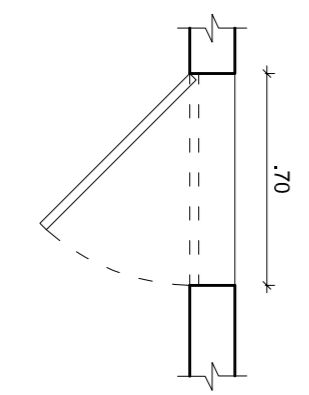

16 PORTA P07
ESCALA: 1:25

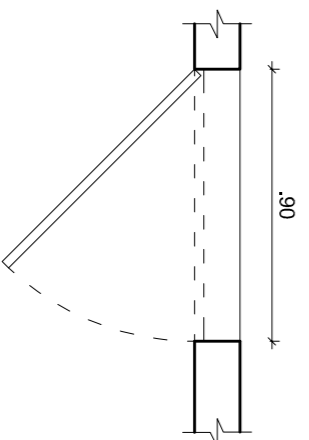

17 PORTA P08
ESCALA: 1:25

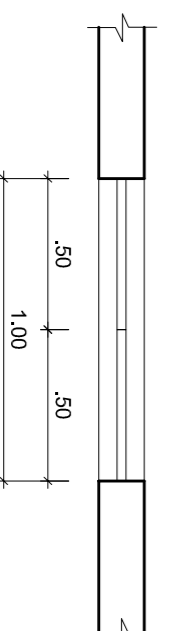

20 JANELA J08
ESCALA: 1:25

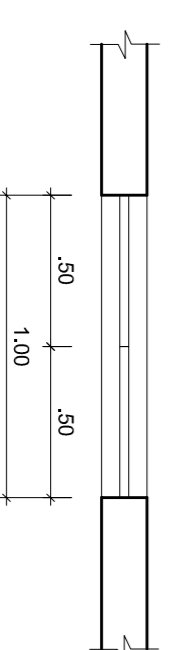

21 JANELA J09
ESCALA: 1:25

- LEGENDA - PISO TÁTIL DE ALERTAS:**
- Piso tátil alerta de borda sintética flexível, de sodéopor (sob o piso ordinário), placas medindo 250x250x5 mm (área interna). Cor: preto.
 - Piso tátil direcional de borda sintética flexível, de sodéopor (sob o piso ordinário), placas medindo 250x250x5 mm (área interna). Cor: preto.
 - Piso tátil alerta de concreto, placas 25x25x2 cm (área externa). Cor: vermelho.
 - Piso tátil direcional de concreto, placas 25x25x2 cm (área externa). Cor: vermelho.

ASSINATURA DO PROJETISTA

ASSINATURA DO RESPONSÁVEL TÉCNICO

ASSINATURA DO CONSTRUTOR

PROJETA	PROJETO	Reforma Parcial Daest Campus João Pessoa
PROJETA	PROPRIETÁRIO	IFPB
PROJETA	ENDEREÇO	Av. Primeiro de Maio, 520, Jaguaribe, João Pessoa - PB
PROJETA	DATA	
PROJETA	RESPONSÁVEL	Engenheiro Civil - Arquiteta
PROJETA	RESPONSÁVEL	Engenheiro Civil - Arquiteta
PROJETA	PROJETO	Engenheiro Civil - Arquiteta
PROJETA	REVISÃO	Engenheiro Civil - Arquiteta
PROJETA	CORREÇÃO	Engenheiro Civil - Arquiteta
PROJETA	ESCALA	1:25
PROJETA	DETALHES	Detalhes Portas e Janelas
PROJETA	INSTITUTO FEDERAL	INSTITUTO FEDERAL Paraíba
PROJETA	PROJETA	PROJETA